

LTM Level Probe

Accurate and Effective Pulp,
Slurry and Water Level
Measurement



Instrumentation

Flotation

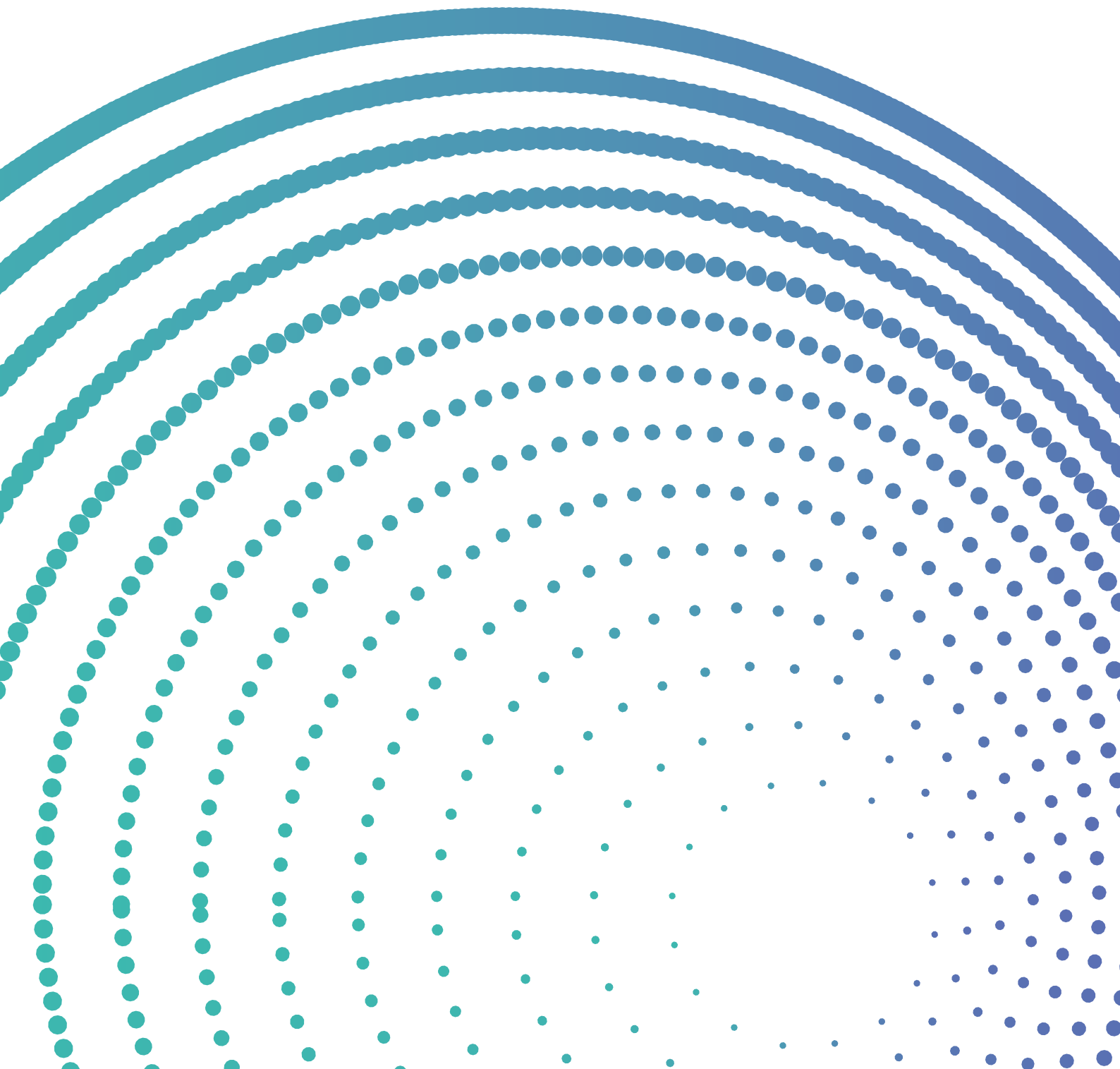

LTM Level Probe Overview

The LTM-2 level sensor provides accurate level measurement for the mining industry in various applications - typically in flotation banks, individual flotation cells or in concentrate sumps to provide consistent accurate pulp level. The unique measuring principle of the LTM-2 allows it to measure the slurry level and ignore the froth component of the flotation cell.

Technologies such as float balls and ultrasonic targets are often adversely affected by the build-up of froth, foam and solids, however, these conditions have no effect on the LTM-2 probe as it has no moving parts. LTM-2 probes are engineered to be robust and will generally provide years of operation when installed correctly.

Features

- Compact and robust sensor with minimal size ratio
- 2-wire sensor with 4...20 mA output signal
- No adjustment after media change due to potentiometric measurement principle
- Individual parameter adjustment or programming via PC interface
- Plug and Play sensor with M12-plug as electrical connection
- Current signal for measurement range, dry signal and error signal adjustable.

Range of Application

Continuous level measurement in metallic vessels up to 3 m in height:

- Ideal for adhesive and pasty media
- Level measurement of foaming media
- Minimum product conductivity 1 $\mu\text{S}/\text{cm}$
- Substitute for float sensors
- For media with homogeneous conductivity.

Application Examples

- Level control in first running vessels of dosing plants
- Suitable for measuring the level in small vessels with overpressure
- Flotation cell level control
- Sump level control.

Design/Process Connection

- Process connection G1.5" (see product information CLEANadapt)
- Sensor made of stainless steel (protection class IP 69 K)
- Process temperature up to 140 °C.

Options/Accessories

- Pre-assembled connecting cable for M12-plug
- Programming adapter MPI-200 with PC software.

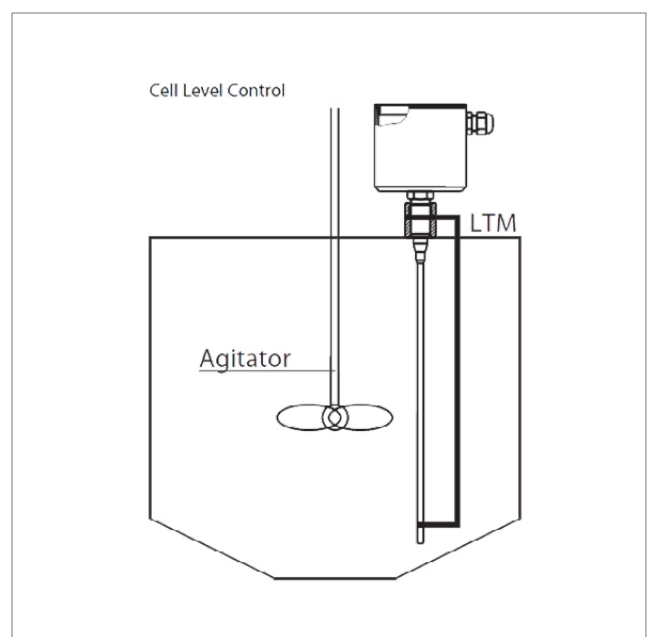

Functional principle

The potentiometric measuring principle measures the change in the voltage ratio between the electrode rod of the sensor and the metallic wall of the filled tank. An electric flow field arises in the medium due to the conductivity of the medium and its capacitive properties. This gives rise to a voltage ratio that is proportional to the immersed part of the rod.

Because only the ratio of the voltages is considered, the properties of the medium, in particular the electrical conductivity, do not enter into the measurement result. The sensor also provides information on the immersion situation of the electrode rod in the medium by means of a second, patent-pending measurement system. This system analyzes electrical resonance properties to detect foam and suppress it in the results, and to reliably prevent erroneous measurements due to adhesions.

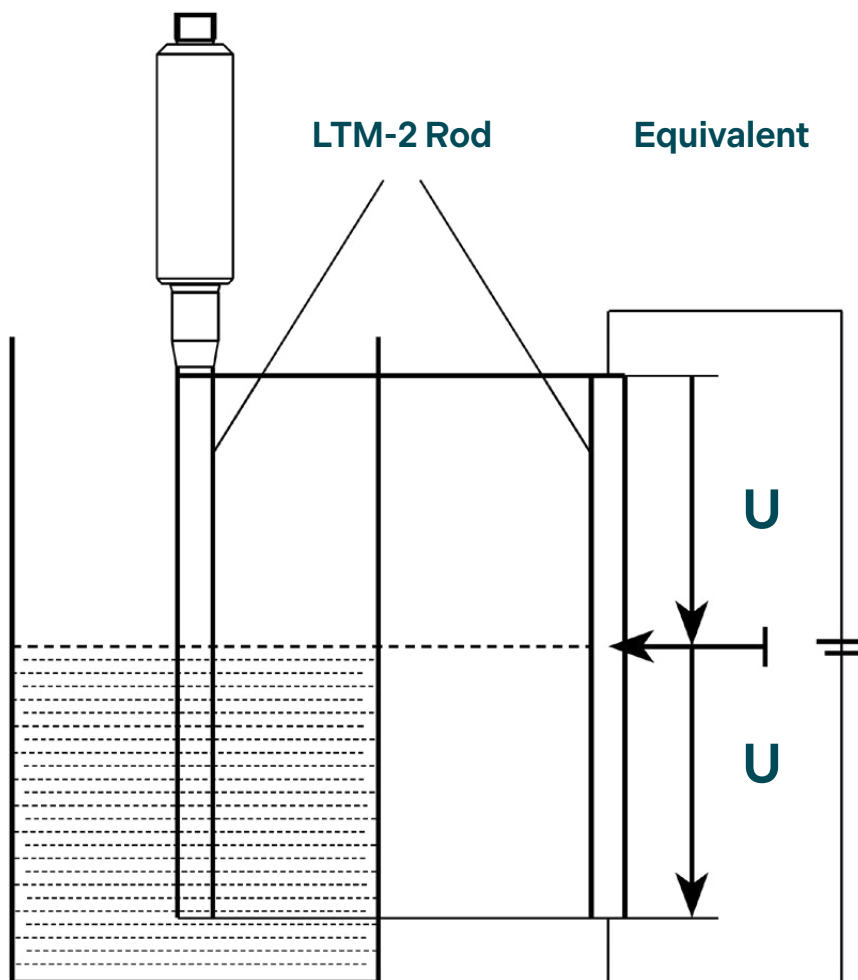

Specifications / Additional Information

Specifications

| Description | Details | Value Limits |
|-----------------------|--|---|
| Rod length EL | | 3000 mm max. |
| Rod diameter | | 10 mm |
| Measurement range | | 50...3000 mm |
| Process connection | thread | G1.5" |
| Process pressure | | max. 16 bar |
| Tightening torque | | 10 Nm |
| Materials | head adapter isolating part rod | stainless steel 1.4305 stainless steel 1.4301 PEEK stainless steel 1.4404, Ra ≤ 0.8 µm |
| Temperature range | ambient storage process | 0...70 °C -40...85 °C -10...140 °C |
| Level measurement | parameters/settings | see table |
| Resolution | rod length > 500 mm rod length < 500 mm | < 0.1 % of upper range value (= rod length) < 0,5 mm |
| Linearity | | < 1.0 % of upper range value (= rod length) |
| Reproducibility | rod length > 500 mm rod length < 500 mm | < 0.2 % of upper range value (= rod length) < 1,0 mm |
| Response time | | < 100 ms |
| Supply | | 19...36 V DC |
| Output | signal burden parameters/settings | analog 4...20 mA, galvanic separated to housing, 2-wire loop see separate graphic see table |
| Electrical connection | | M12-plug, 1.4301, 4-pin |
| Protection class | | IP 69 K |
| Weight | | 550 g with rod length 1.5 m |

4...20 mA current signal

| | |
|--|---|
| Underrange | 3.80; 3.95; 4.00 mA |
| Overrange | 20.00; 20.05; 20.50 mA |
| Warning and failure signal (e.g. dry run) | 3.80; 3.95; 4.00mA 20.00; 20.05; 20.50; 21.00; 21.20 mA |
| Level measurement | |
| Zero/Gain | -50...50% / 50...150% |
| Damping | 0; 0.1; 0.2; 0.5; 1; 2; 5 s |

Possible Parameter / Settings.

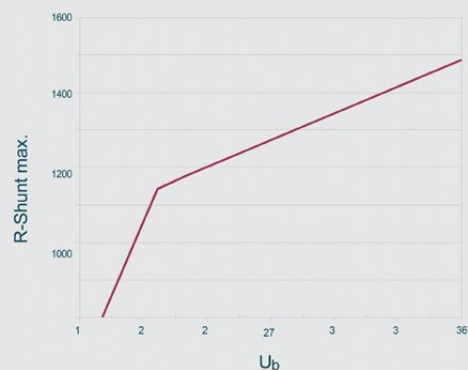

Burden.

Advice / Dimensional Drawing

Conventional Usage

- Not suitable for applications in explosive areas
- Not suitable for applications in security-relevant equipments (SIL).

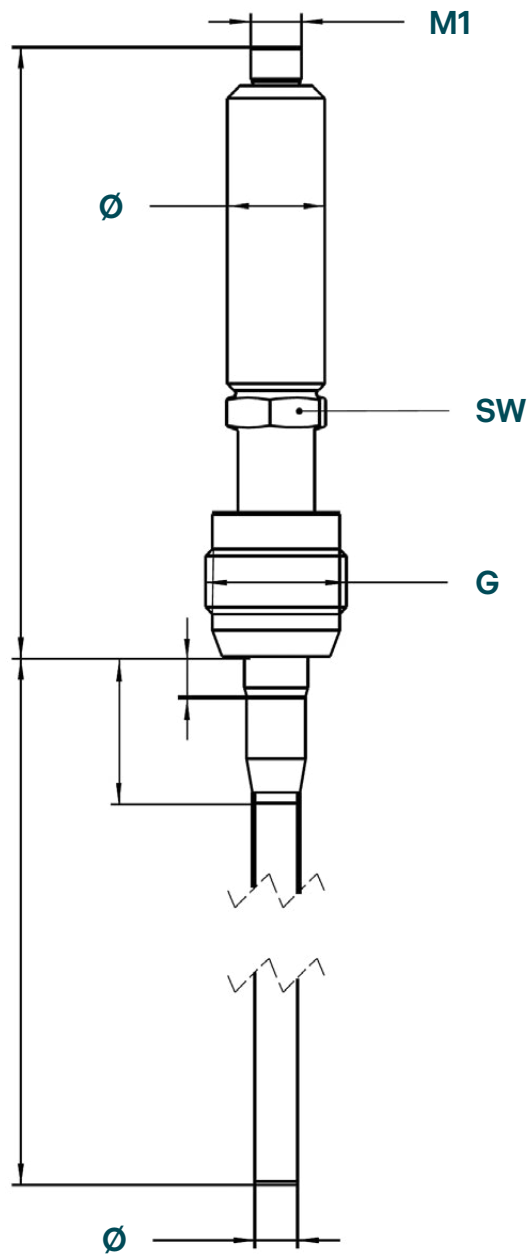

Dimensional Drawing LTM-2.

Installation / Electrical Connection

Mechanical Connection / Installation

- **Attention! Do not shorten the sensor rod!**
- To guarantee a safety function of the sensor, the G1.5" thread must have a good electrical contact to the vessel wall!
 - Because of this, do not use any sealing materials like Teflon or others!
- The sensor rod must not have any electrical contact to the vessel wall! Please also attend that the rod may swing if there are turbulences in the vessel!
- In Flotation Cells, non-metallic and/or rubber lined vessels, the LTM-BRK bracket needs to be used in conjunction with the LTM level probe.

Cable with M12-Plug and LED

- The LTM-2 Sensor is a 2-wire sensor with 4...20 mA output signal. Use of a cable with internal LEDs will cause a measurement error.

Power Supply Cable

- To guarantee a trouble-free function, the power supply cable should be shielded and grounded at the electrical control box.

- 1: +supply
- 2: -supply 4...20 mA
- 3: data link to PC interface, must not be connected
- 4: data link to PC interface, must not be connected

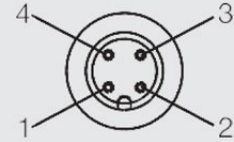

Configuration M12-Plug.

- 1: PLC
- 2: M12-plug
- 3: 4...20 mA current loop

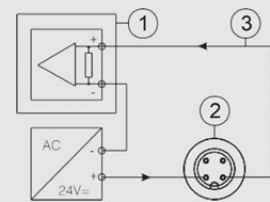

Configuration M12-Plug.



M12-Plug with LED.

Parametrization



Programming Adapter MPI-200.

- 1: External power supply
via M12-plug (optional)
- 2: USB port for connection
to PC incl. power supply
if not supplied external
- 3: Connection cable to

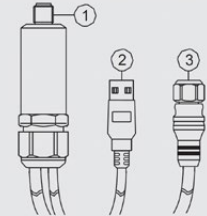

Connection of Programming Adapter MPI-200.

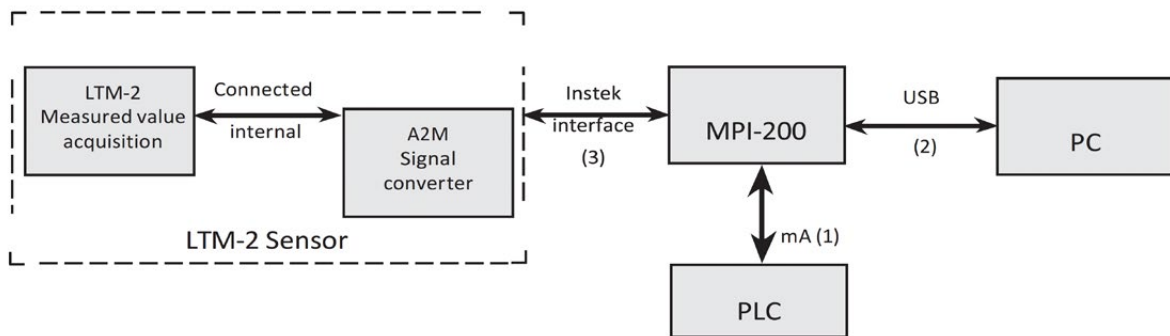

Signal Flow with Parametrization.

Adjustment of LTM-2 Parameters

Using the PC based software and the programming adapter MPI-200 the following NSL-M parameters can be adjusted or changed in situ (with vessel) or alternatively on the bench (in simulation mode): e.g.

- 4...20 mA Signal
 - Level for (4 / 20) mA output signal
 - Warning signal "dry run"
 - Error signal "failure"
 - Signal limit for under- and overrange
 - Error signal "over- and underflow"
 - Signal simulation (3.80...21.20 mA)
- Level measuring
 - Level zero / offset
 - level slope / gain
 - Damping / filter
 - Physical Unit
- Mounting position

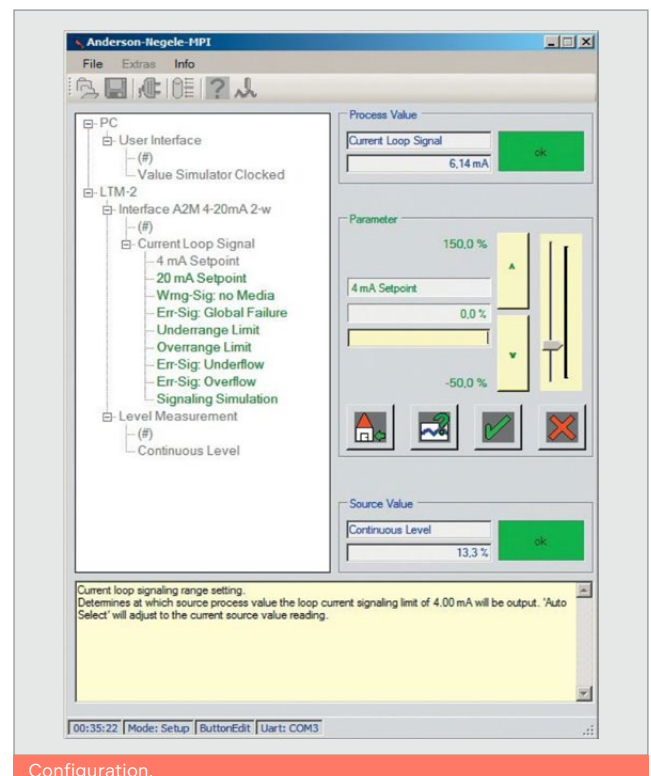

Configuration.

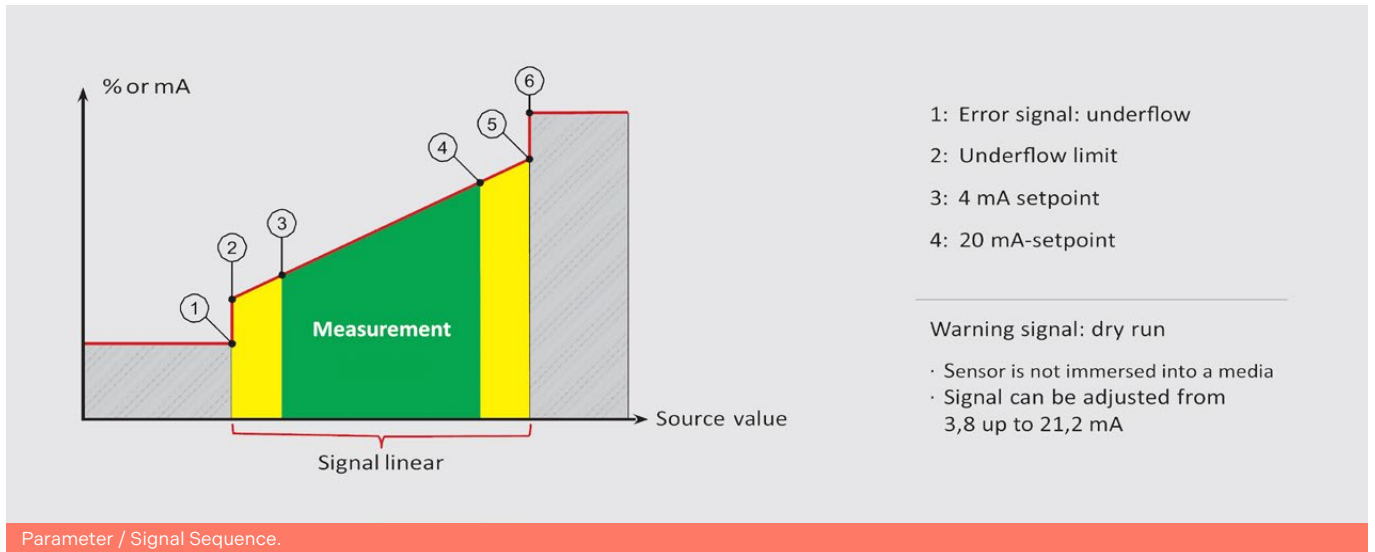

Note

- A list of the parameter settings in the level switch is supplied with the device. These parameter settings and those changed by the user can be printed out in the software using the MPI-200 programming adapter.
- When making settings, note the help texts in the MPI software. They provide useful information on changing the selected parameter.

The default setting of the LTM-2 level switch is for operation with aqueous media without requiring special adjustments. In exceptional cases involving highly critical media or special tank contours (with internal structures such as a pipe), it may be necessary to make adjustments to some of the parameters (the parameter can be found under the path specified below):

For installation from above or adhesions between the rod end and wall for installation from below

Setup Menu

- LTM-2
 - Level Measurement
 - Continuous Level
 - Adhesive Detection
Smaller values result in better suppression

Coarse adjustment of adhesion detection.

For installation from above or adhesions between the rod end and wall for installation from below

Setup Menu

- LTM-2
 - Level Measurement
 - Continuous Level
 - Adhesive Det. Hysteresis
Reduction of coarse setting by set value

Fine adjustment of adhesion detection.

In case of foam or adhesions to the lower end of the switch (4 mA signal)

Setup Menu

- LTM-2
 - Level Measurement
 - Dry Run Detection
 - Sensitivity Optimization
Set to the desired value of the parameter list

Coarse adjustment of sensitivity.

Fine adjustment for detecting the medium

Setup Menu

- LTM-2
 - Level Measurement
 - Dry Run Detection Threshold Fine
 - Threshold Fine Tuning
Smaller values create a higher sensitivity

Fine adjustment of sensitivity.

To damp signal jumps at the lower end of the sensor (4 mA signal)

Setup Menu

- LTM-2
 - Level Measurement
 - Dry Run Detection Hysteresis
 - Larger values result in better signal suppression

Prevention of signal jumps in turbulent media.



Parametrization / Advice

System Parameter Suggestion

- To generate the system parameter suggestion, there should be no media in the vessel.

Transport / Storage

- No outdoor storage
- Dry and dust free
- Not exposed to corrosive media
- Protected against solar radiation
- Avoiding mechanical shock and vibration
- Storage temperature -40°C...+85°C
- Relative humidity maximum 98%.

Notice on Conformity

Applicable guidelines:

- Electromagnetic compatibility 2004/108/EC
- The accordance with applicable EU-guidelines is confirmed with CE-labelling of the device
- You have to guarantee the compliance of all guidelines applicable for the entire equipment.

Cleaning / Maintenance

- In case of using pressure washers, don't point nozzle directly to electrical connections!

Reshipment

- Sensors and process connection shall be clean and must not be contaminated with dangerous media and/or heat-conductive paste! Note the advice for cleaning!
- Use suitable transport packaging only to avoid damage of the equipment!

Standards / Guidelines

- You have to comply with applicable regulations and directives.

Disposal

- This instrument is not subject to the WEEE directive 2002/96/EC and the respective national laws
- Pass the instrument directly on to a specialised recycling company and do not use the municipal collecting points.



Programming Adapter MPI-200.



Application Sample.



LTM-2 (potentiometric level sensor for mining application, 2-wire technology, connecting head = 23 mm, wetted material 1.4404, electrical connection M12-plug, dry run adjustment to 4 mA)

Version

00 (standard)

Rod length EL, choose length in a 10 mm raster, e.g.: 220, 230, 240 etc., max length 3000 mm.

50...3000 (material 1.4404)

Process connection

G15 (standard thread G1.5")

Installation position

O (installation from top)

Output signal

A2M (4...20 mA, analog, 2-wire)

Parameter configuration

X (standard, measurement length = rod length)

RM XXX (active measurement length measured from rod end)

Order Code



If you're interested
in exploring Molycop's
products and services,
we're here to help.



molycop.com

All Rights Reserved 2024

This publication has been prepared by Moly-Cop Global Holdings Inc. on its behalf and as agent for each of its related companies. All information contained in this publication is subject to change, replacement and/or modification at any time, without notice. Moly-Cop Global Holdings Inc. expressly disclaims all warranties, whether expressed or implied, oral or written, including any implied warranty of merchantability, fitness for a particular purpose, non-infringement, or other warranties arising from course of dealing, course of performance, usage of trade, or otherwise. The information is provided on an "as is" and "as available" basis. The information is provided for informational purposes only and Moly-Cop Global Holdings Inc. does not warrant the accuracy of any information or that the information will be error-free. Users of this publication are responsible to verify the accuracy and completeness of all information. Moly-Cop Global Holdings Inc. shall have no liability for any losses or damages of any kind arising out of or resulting from this publication, its contents and any use thereof.

Photographs shown are representative only of typical applications and are current as of August, 2023. This publication is not an offer to trade and shall not form any part of the trading terms in any transaction.

Reproduction in whole or in part, in any form or medium without the express written permission of Moly-Cop Global Holdings Inc. is prohibited. All images and content, trademarks or registered trademarks are the property of Moly-Cop Global Holdings Inc.

