

# Cement MillScan

Increase Throughput  
& Reduce Energy  
Consumption



Instrumentation

Milling

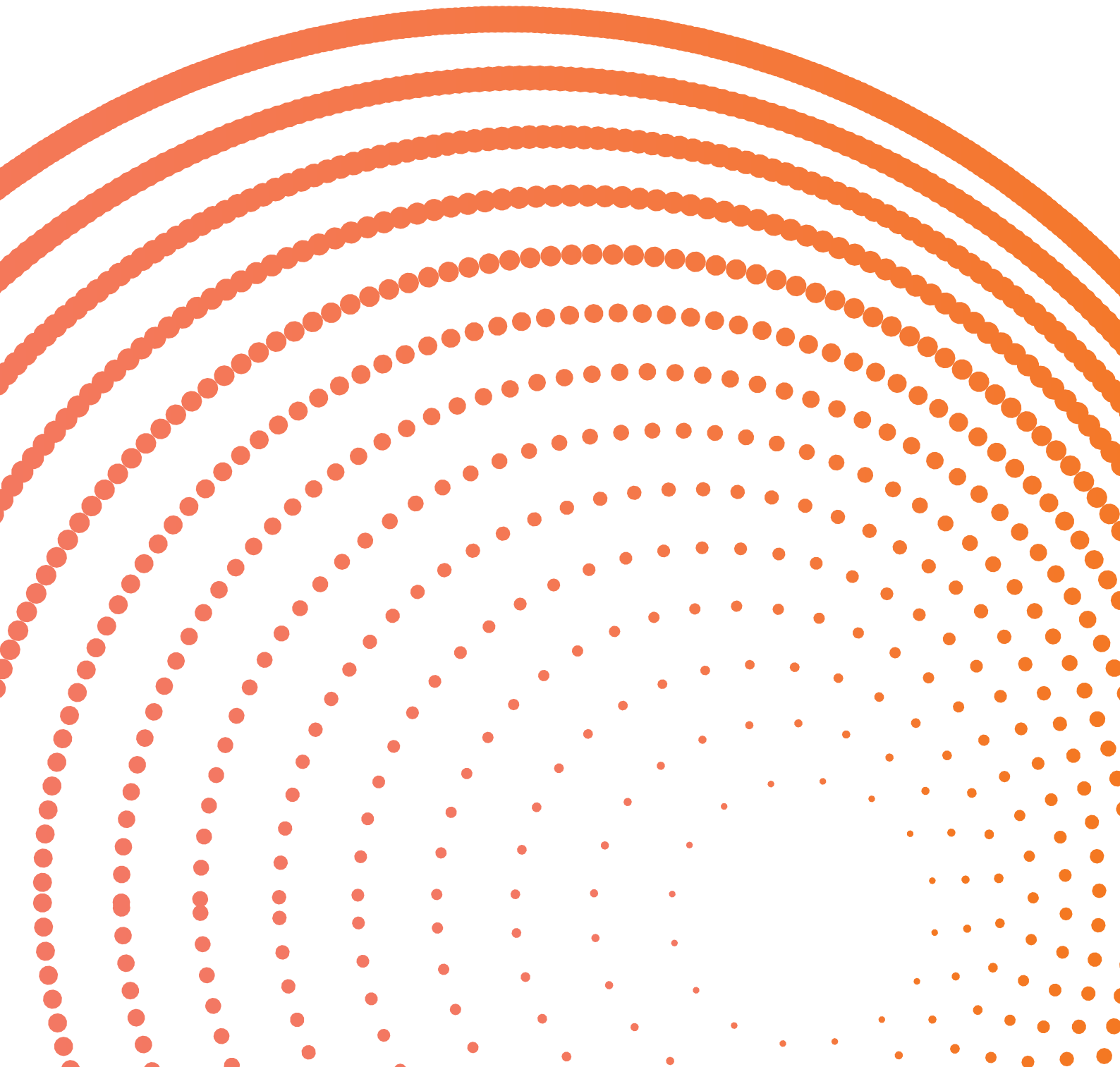

## Cement MillScan Overview

Cement MillScan is a next-generation instrument used to increase profitability of a cement-producing operation by increasing throughput and reducing energy costs.

Cement MillScan uses vibration-based technologies to measure mill volume fills in single, double, or triple compartment mills at high frequency allowing efficient manual or automated expert control of the milling circuit.

With more than 400 installations globally and 15 years of experience, Molycop's (formerly Process IQ) Cement MillScan is the global leader in mill vibration technologies.

### Benefits

- **Optimised milling throughput**  
Controlling the mill fill level rather than bearing pressure increases milling capacity
- **Increase mill efficiency**  
Improve mill power utilisation by grinding optimally
- **Reduce opex**  
Reduce ball consumption/ton milled. Reduce liner wear by operating the mill at an optimal fill level.

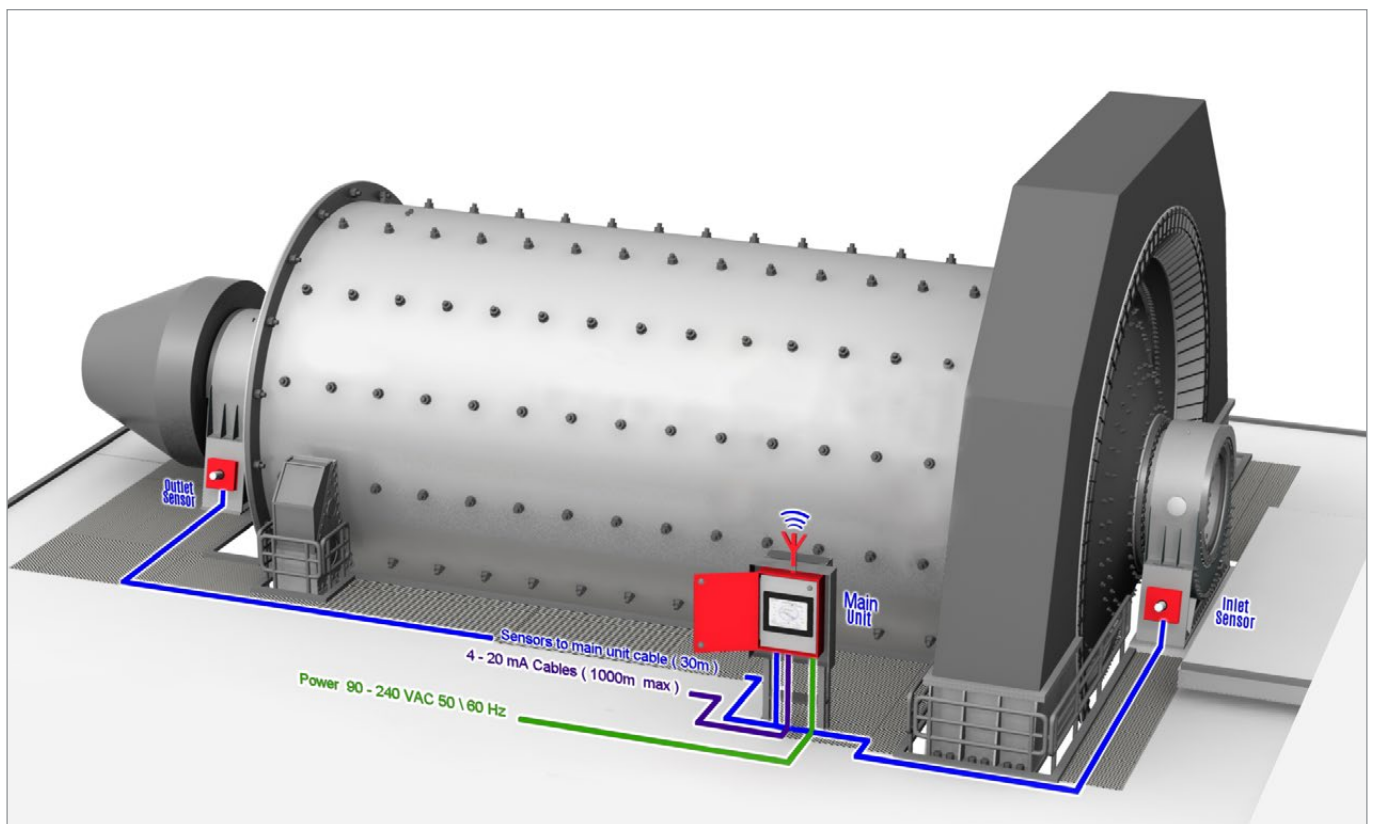

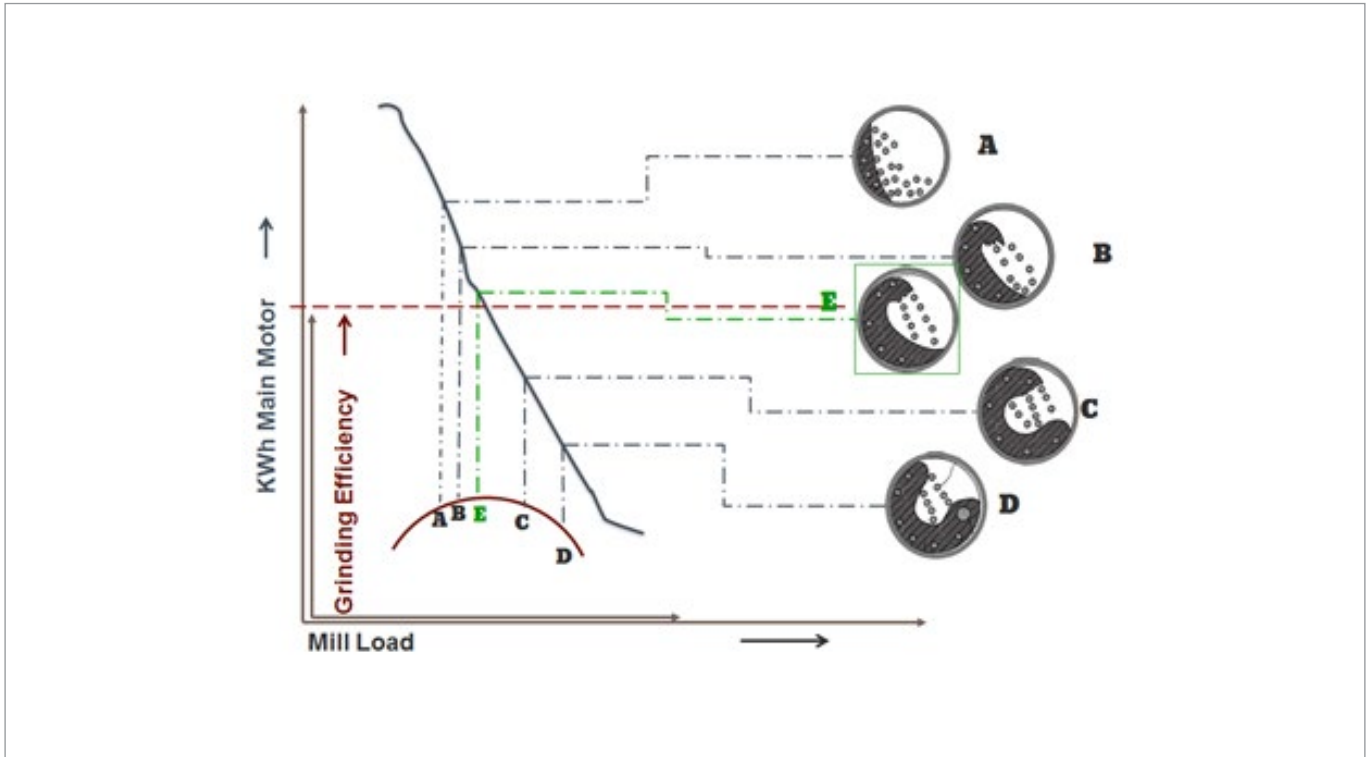

## Optimised Milling

Optimal milling happens at the peak of the mill to power curve where steel balls impact the toe of the load as illustrated in E. Most operations run closer to A thus expending more energy than required and damaging liners in the process.

Cement MillScan provides the necessary measurements to operate a ball mill at optimal power to load ratio maximising throughput, minimising energy consumption, and maximising liner life.

Molycop's Advanced Process Control solutions also provide the necessary technologies to automate control with the input from the Cement MillScan to achieve optimised milling.

## Features

- Precise mill fill level measurement that can be used to increase the ROI of your existing mill
- Zero cross talk from adjacent (nearby) mills
- All digital system, no component drift, not affected by temperature, dust or dirt as is the case in typical mic based systems
- 4-20mA output for traditional automated loop control in the production control room
- 3X resolution when compared to microphone-based systems
- Fast and easy installation that typically can be performed in less than two hours and does not require mill shutdown
- A quick calibration procedure that can be performed in less than 5 minutes per sensor when the mill is operating under normal conditions. i.e. The mill is filled to a level that is used in normal 'day to day' production
- Signal sensitivity changes can be made very quickly without re-calibrating the unit.



If you're interested in exploring Molycop's products and services, we're here to help.



[molycop.com](https://molycop.com)

© Molycop. All rights reserved 2026.

This publication has been prepared by Moly-Cop Global Holdings Inc. on its behalf and as agent for each of its related companies. All information contained in this publication is subject to change, replacement and/or modification at any time, without notice. Moly-Cop Global Holdings Inc. expressly disclaims all warranties, whether expressed or implied, oral or written, including any implied warranty of merchantability, fitness for a particular purpose, non-infringement, or other warranties arising from course of dealing, course of performance, usage of trade, or otherwise. The information is provided on an "as is" and "as available" basis. The information is provided for informational purposes only and Moly-Cop Global Holdings Inc. does not warrant the accuracy of any information or that the information will be error-free. Users of this publication are responsible to verify the accuracy and completeness of all information. Moly-Cop Global Holdings Inc. shall have no liability for any losses or damages of any kind arising out of or resulting from this publication, its contents and any use thereof.

Photographs shown are representative only of typical applications and are current as of May 2026. This publication is not an offer to trade and shall not form any part of the trading terms in any transaction.

Reproduction in whole or in part, in any form or medium without the express written permission of Moly-Cop Global Holdings Inc. is prohibited. All images and content, trademarks or registered trademarks are the property of Moly-Cop Global Holdings Inc.

